

LifeFitness

Arctic Silver 93T Treadmill

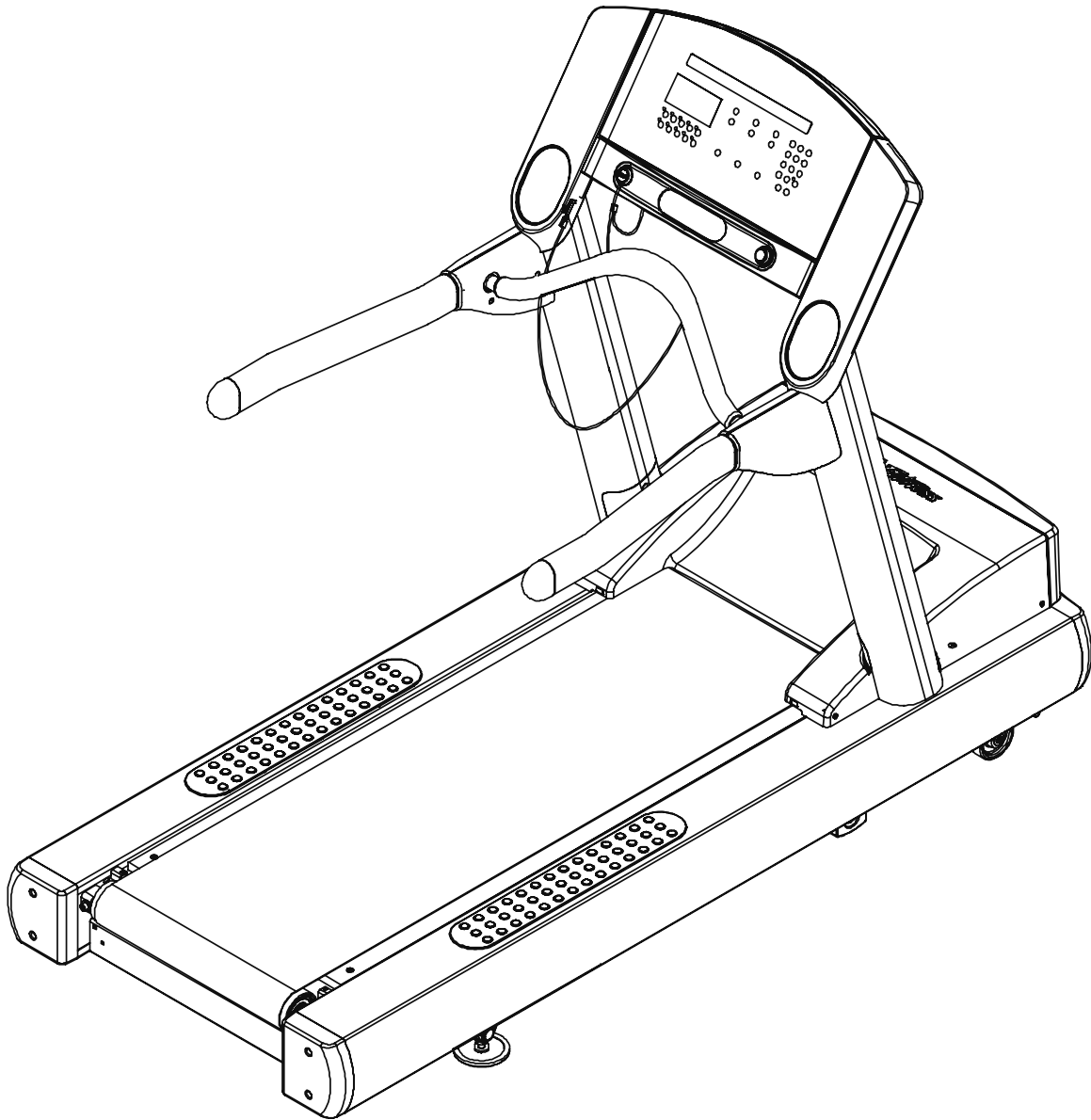

Customer Support Services
PARTS MANUAL rev. 29 Mar 2007

ARCTIC SILVER 93T
REFERENCES

93T-0XXX-03
S/N ATS100000 and up

OPERATION MANUAL	M051-00K58-A173
SERVICE MANUAL	M051-00K58-A159
HARDWARE BAG	AK58-00227-0000
TOUCH UP PAINT: SPRAY CAN .5 OZ BOTTLE W/APPLICATOR .33 OZ PEN	0017-00008-0204 0017-00008-0205 0017-00008-0206
INSTALLATION VIDEO	M051-00K58-A160
SERVICE VIDEO	M051-00K58-A161

	Page
REAR ENDCAPS AND CUP HOLDERS	3
SCUFF PAD, TINSEL AND FRAME TAG BOARD	4
CONSOLE AND RELATED COMPONENTS.....	5
UPRIGHTS, HAND RAILS AND ERGO BAR	6
MOTOR COVER, FRONT COVER AND ENDCAPS	7
BELT, DECK AND REAR ROLLER.....	8
LIFT FRAME AND MOTOR	9
WAX/LIFT ASSEMBLY	10
MOTOR CONTROLLER ASSEMBLY.....	11
DRIVE MOTOR ASSEMBLY	12
IDLER ARM ASSEMBLY AND STATIC BRUSH.....	13
LEG LEVELER ASSEMBLY	14
FRONT ROLLER ASSEMBLY.....	15
POWER COMPONENTS SCHEMATIC	16
CABLES	17

ARCTIC SILVER 93T
Rear End Caps and Cup Holders

93T-0XXX-03
S/N ATS 100000 and up

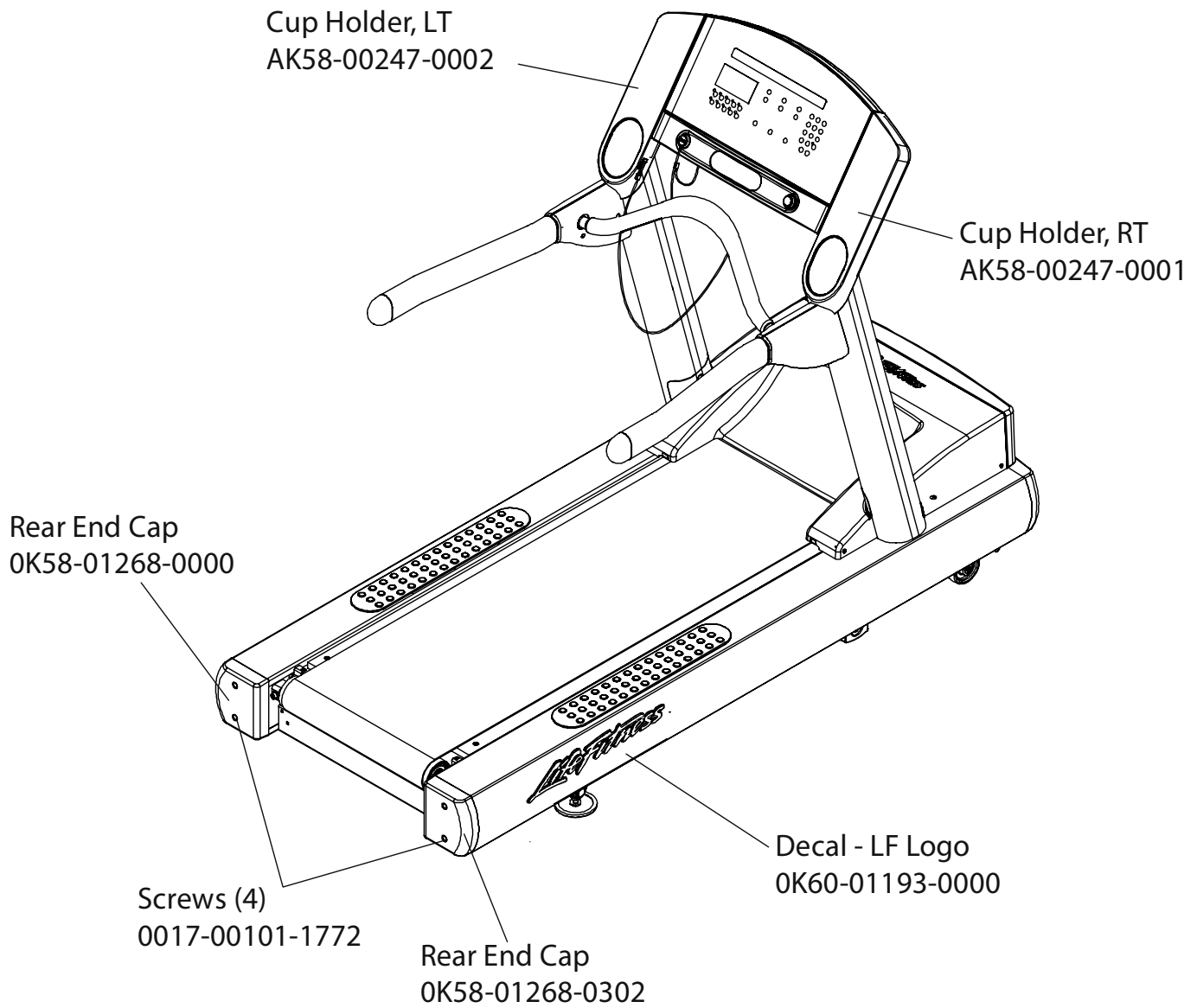

ARCTIC SILVER 93T

Scuff Pad, Tinsel and Frame Tag Bd.

93T-0XXX-03

S/N ATS100000 and up

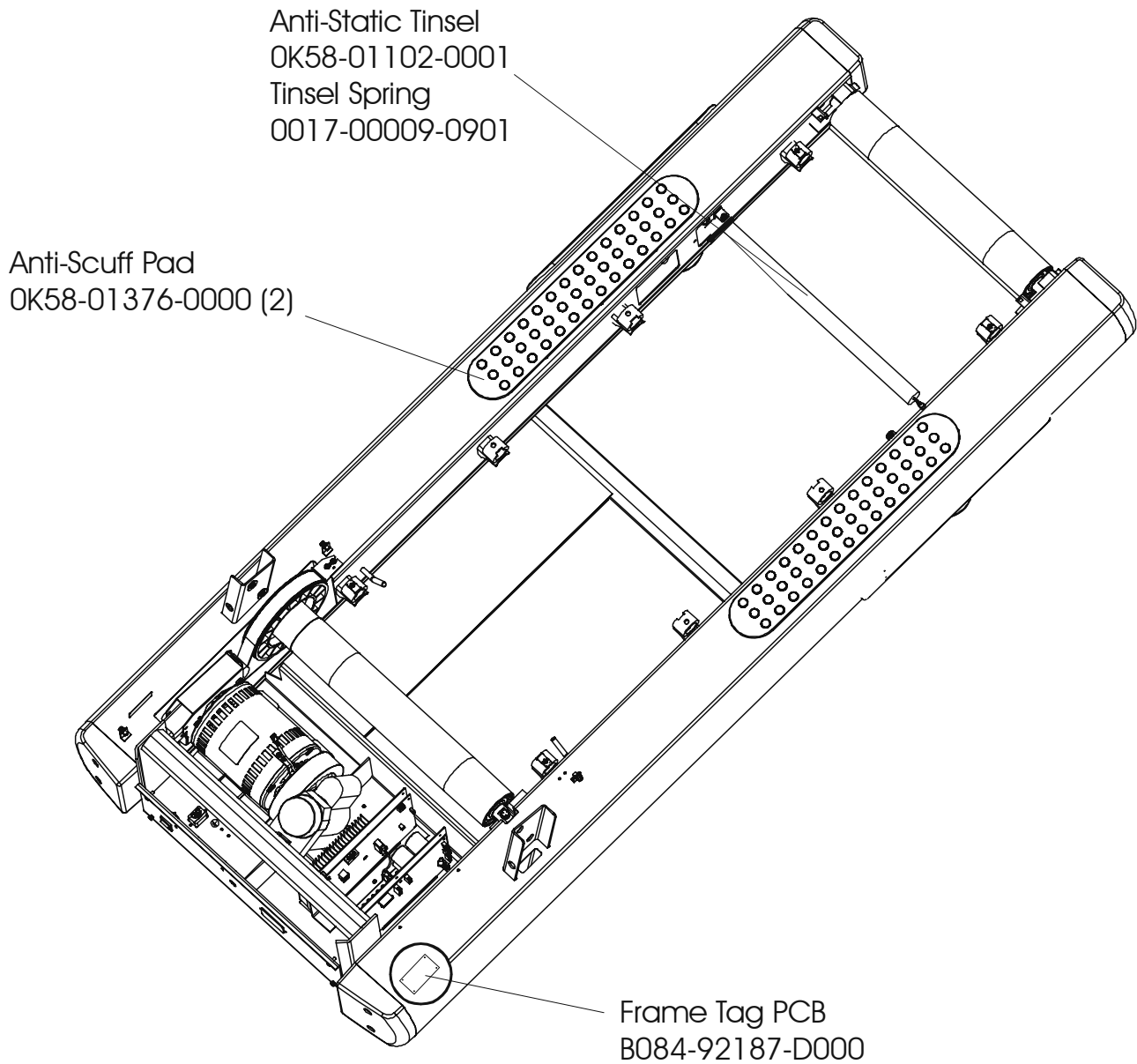

ARCTIC SILVER 93T

Console and Related Components

93T-0XXX-03
S/N ATS100000 and up

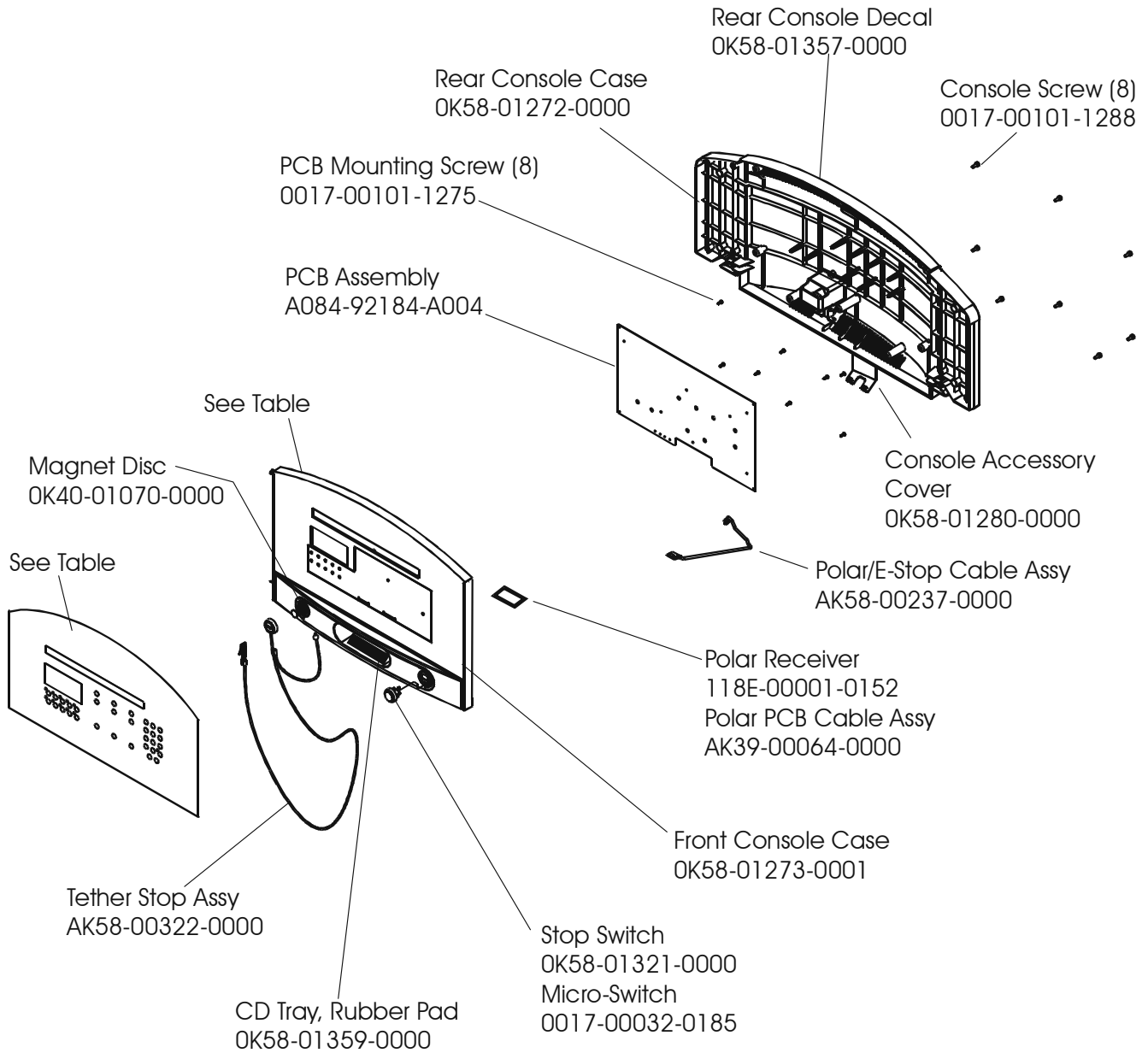

Console Assembly	Overlay/Bezel/Switch Assy.	Language
AK58-00405-0001	AK58-00204-0001	Eng/Met
AK58-00405-0002	AK58-00204-0001	Eng/Eur
AK58-00405-0003	AK58-00204-0003	German
AK58-00405-0004	AK58-00204-0004	Spanish
AK58-00405-0006	AK58-00204-0006	Japanese
AK58-00405-0007	AK58-00204-0007	French
AK58-00405-0008	AK58-00204-0008	Italian
AK58-00405-0009	AK58-00204-0009	Dutch

ARCTIC SILVER 93T

Uprights, Handrails and Ergo Bar

93T-0XXX-03
S/N ATS100000 and up

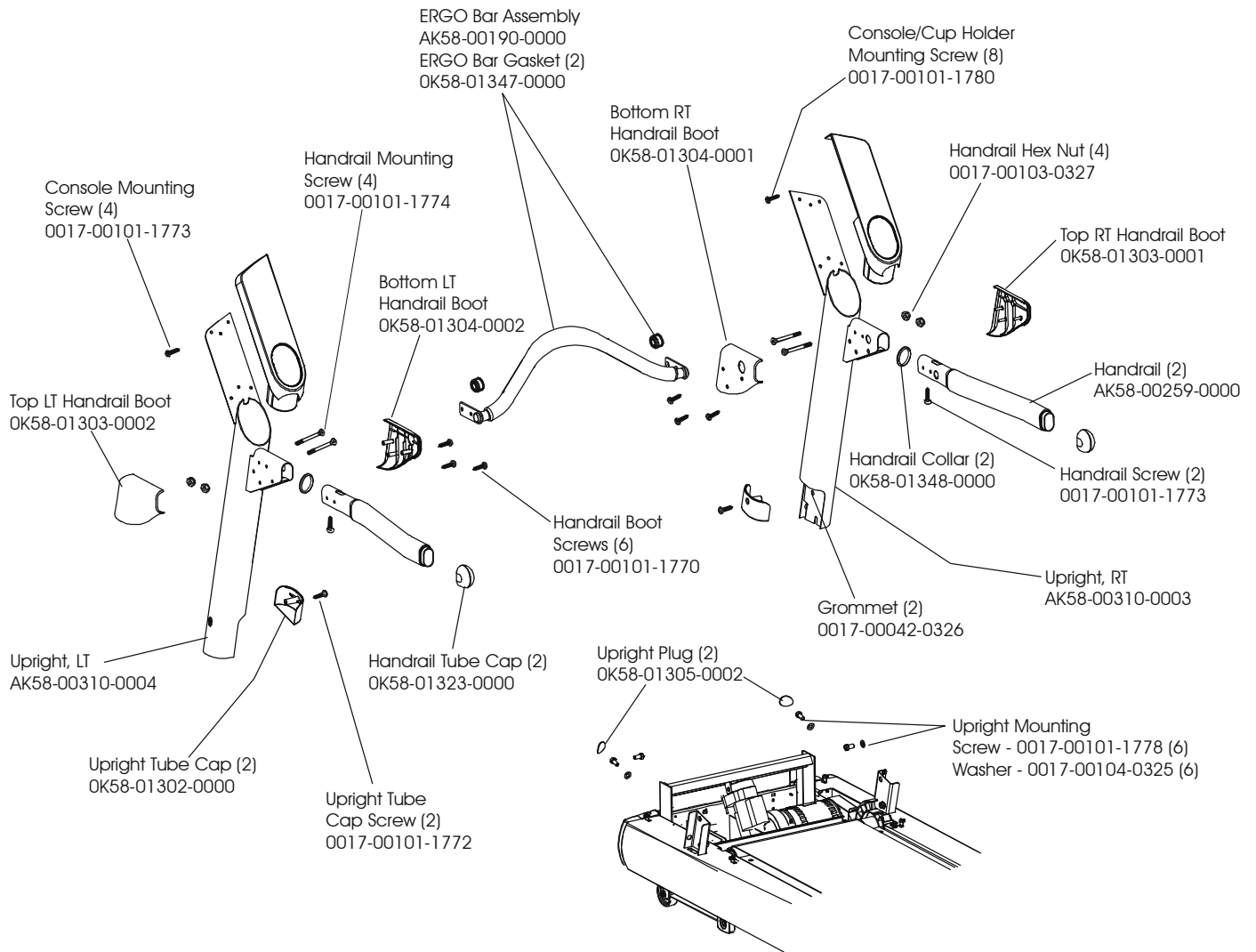

ARCTIC SILVER 93T

Motor Cover, Front Cover and Front End Caps

93T-0XXX-03

S/N ATS100000 and up

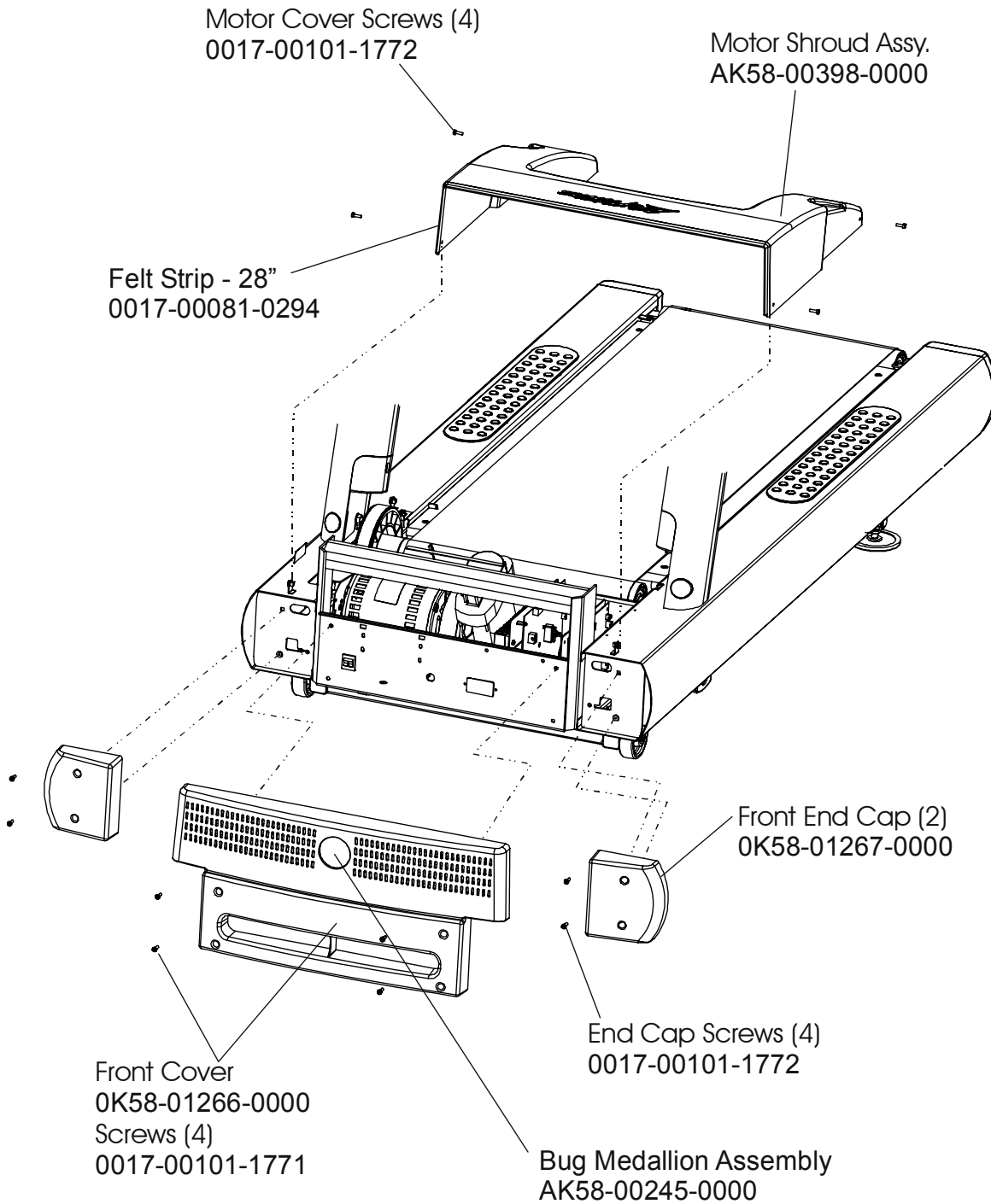

ARCTIC SILVER 93T
Belt, Deck and Rear Roller

93T-0XXX-03
S/N ATS100000 and up

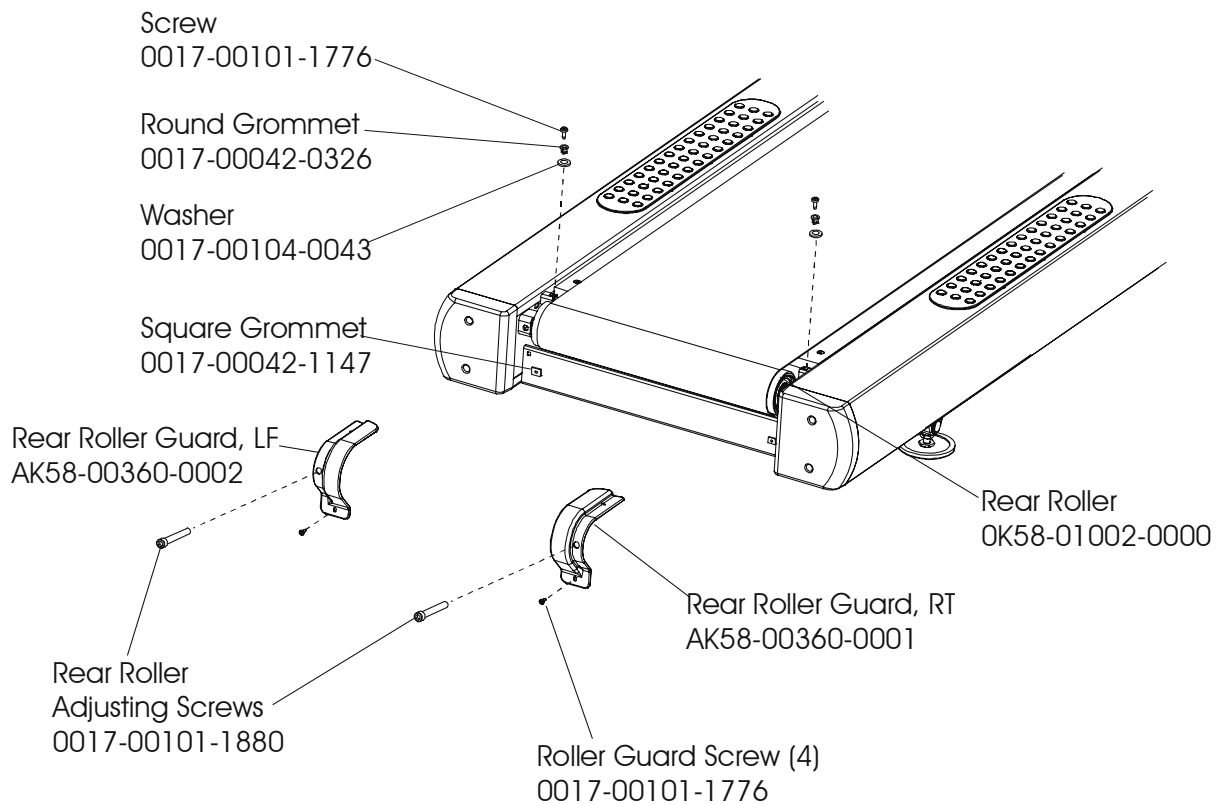
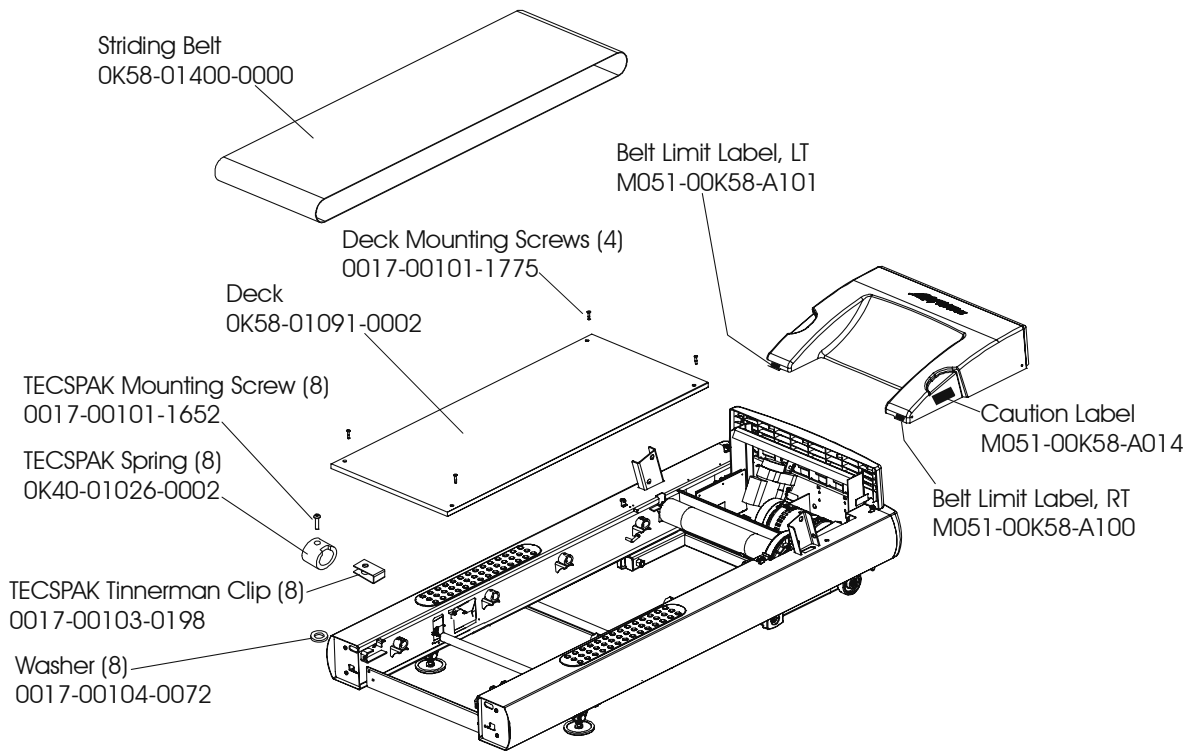

ARCTIC SILVER 93T
Lift Frame and Lift Motor

93T-0XXX-03
S/N ATS 100000 and up

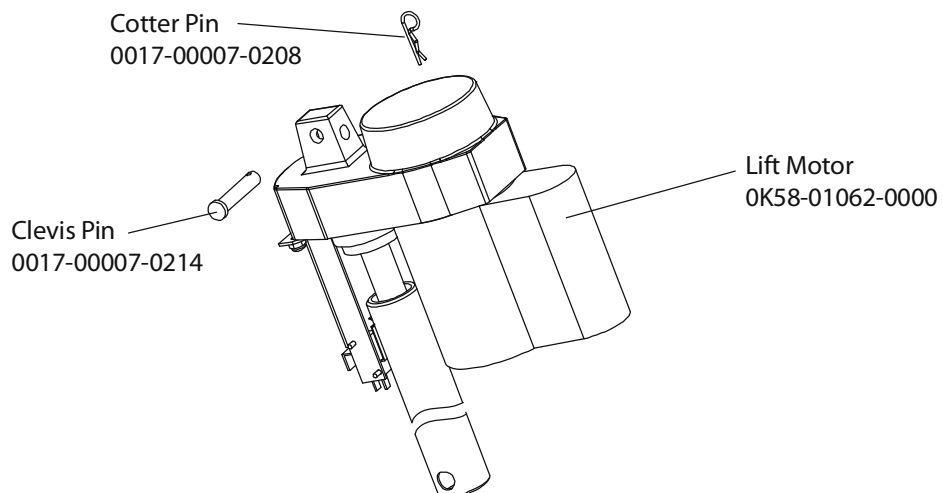
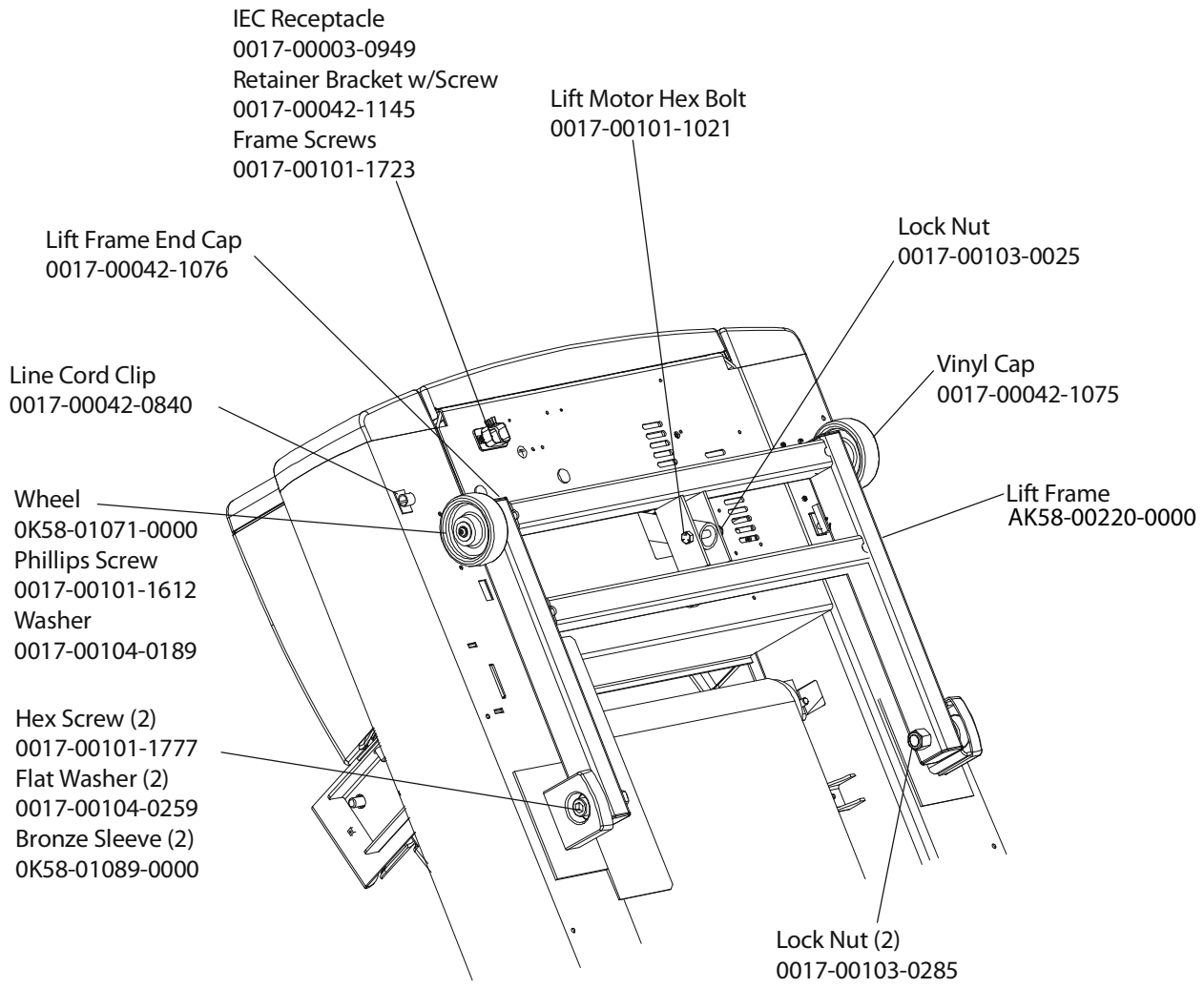

ARCTIC SILVER 93T

Wax/Lift Assembly—AK58-00243-0000

93T-0XXX-03

S/N ATS100000 and up

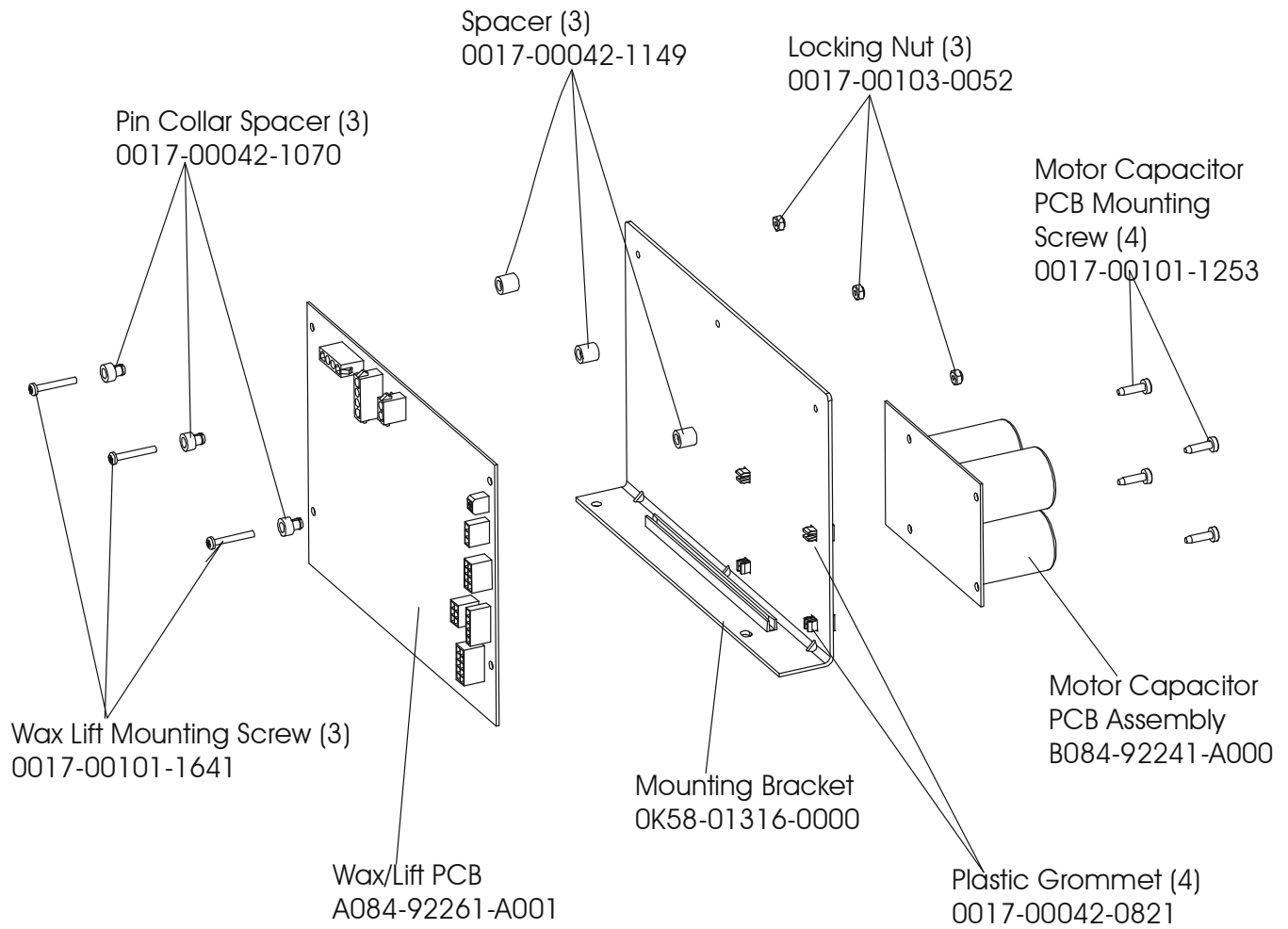

AK60-00171-0000 (100-120V) W/O FERRITE
AK60-00171-0001 (200-240V) W/O FERRITE
AK60-00171-0002 (100-120V) WITH FERRITE
AK60-00171-0003 (200-240V) WITH FERRITE

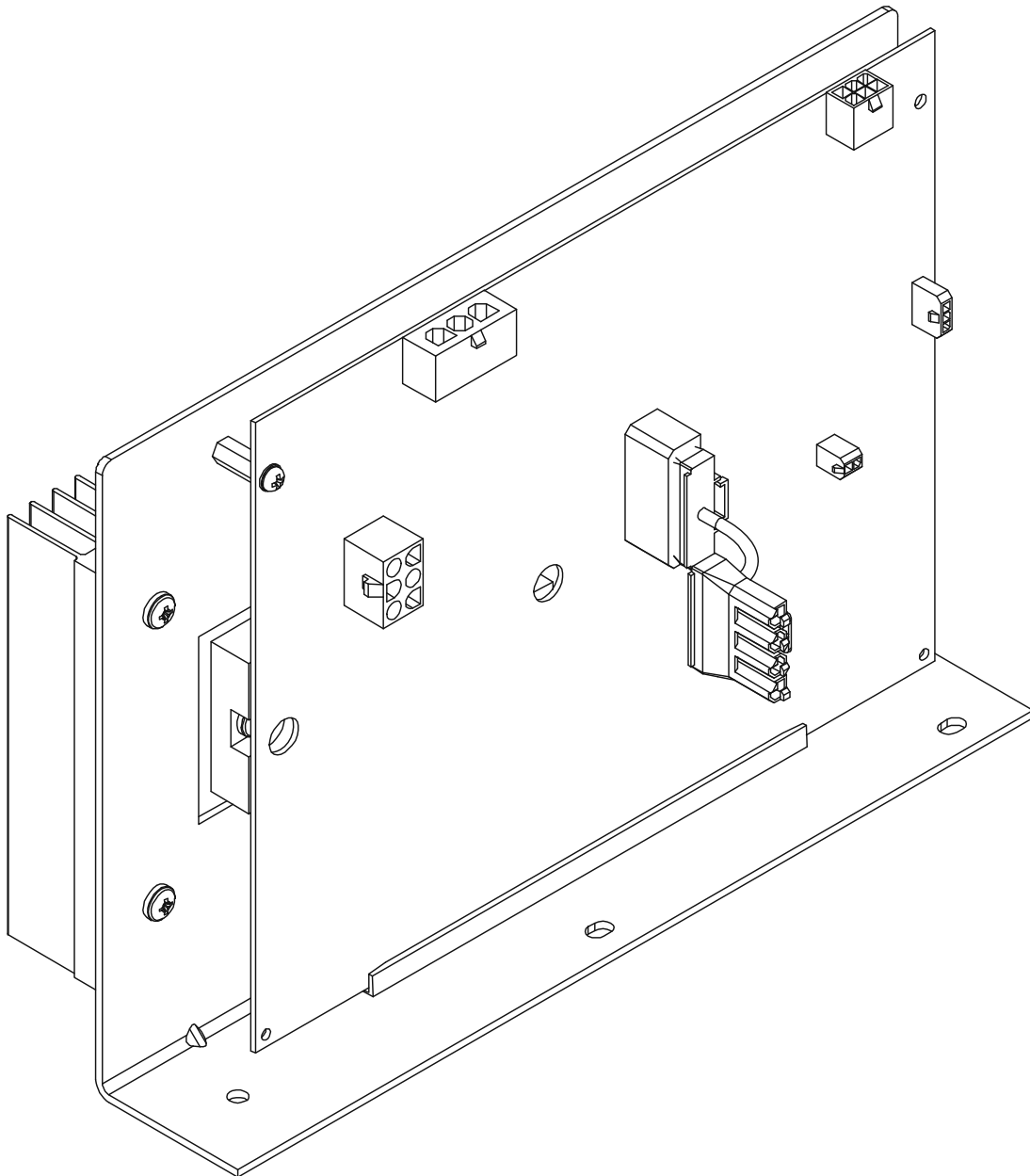

ARCTIC SILVER 93T
Drive Motor Assembly

93T-0XXX-03
S/N ATS100000 and up

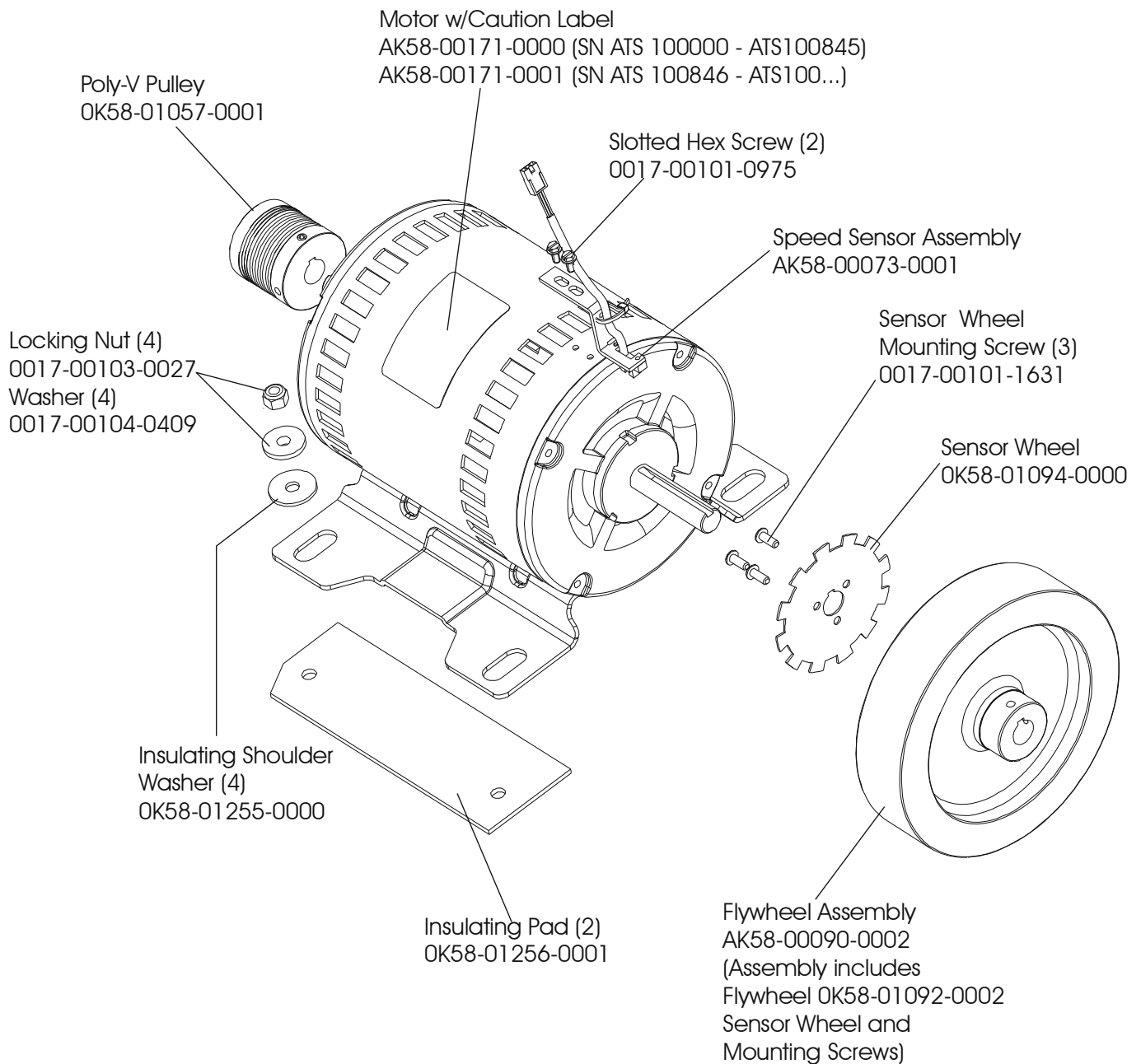

Drive Motor Assembly Number	Motor Serial Number
AK58-00172-0000	ATS100000 – ATS100845
AK58-00172-0002	ATS100846 and up

ARCTIC SILVER 93T

93T-0XXX-03

Idler Arm Assembly and Static Brush

S/N ATS100000 and up

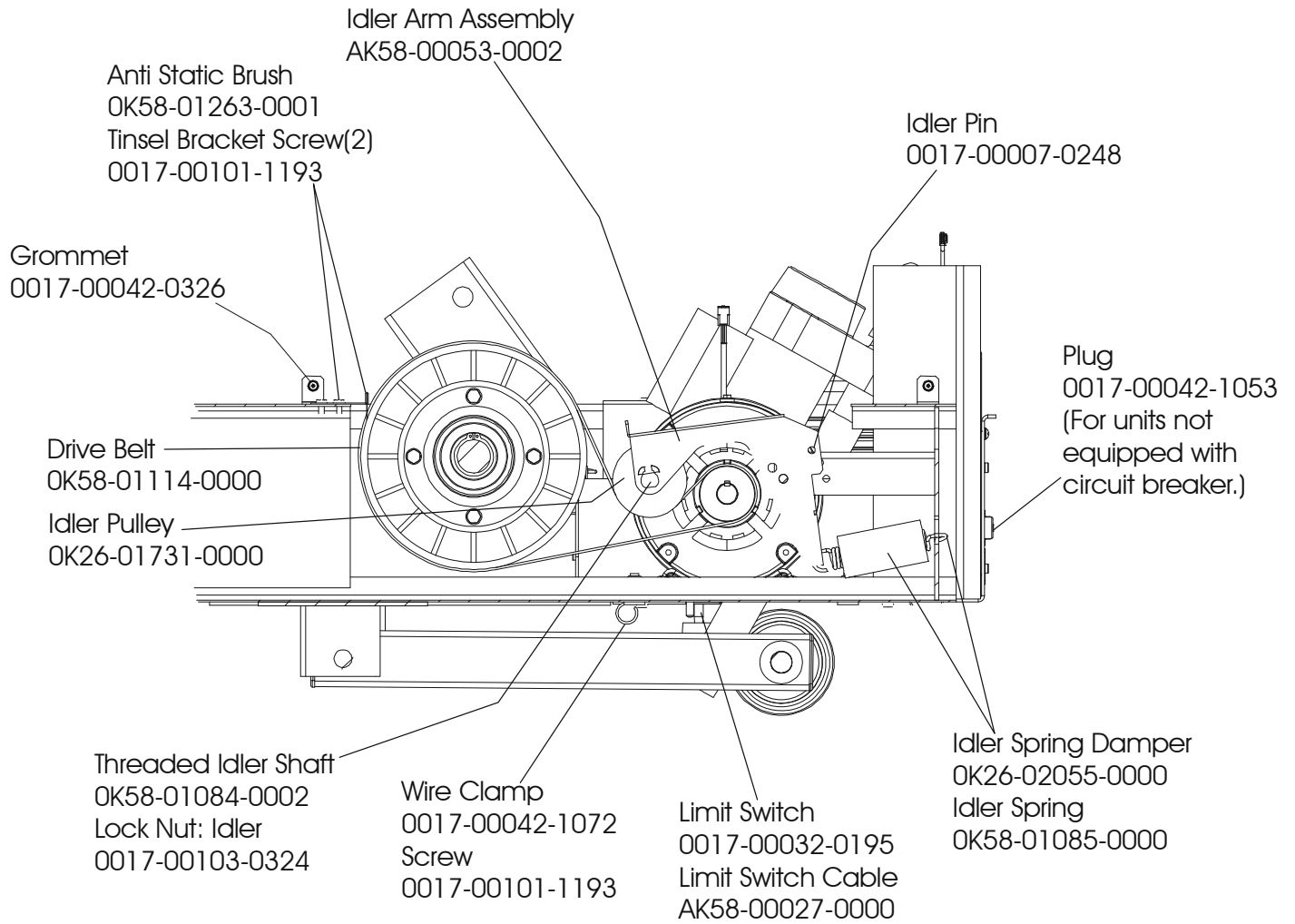

ARCTIC SILVER 93T
Leveler Assembly – AK58-00370-0000

93T-0XXX-03
S/N ATS100000 and up

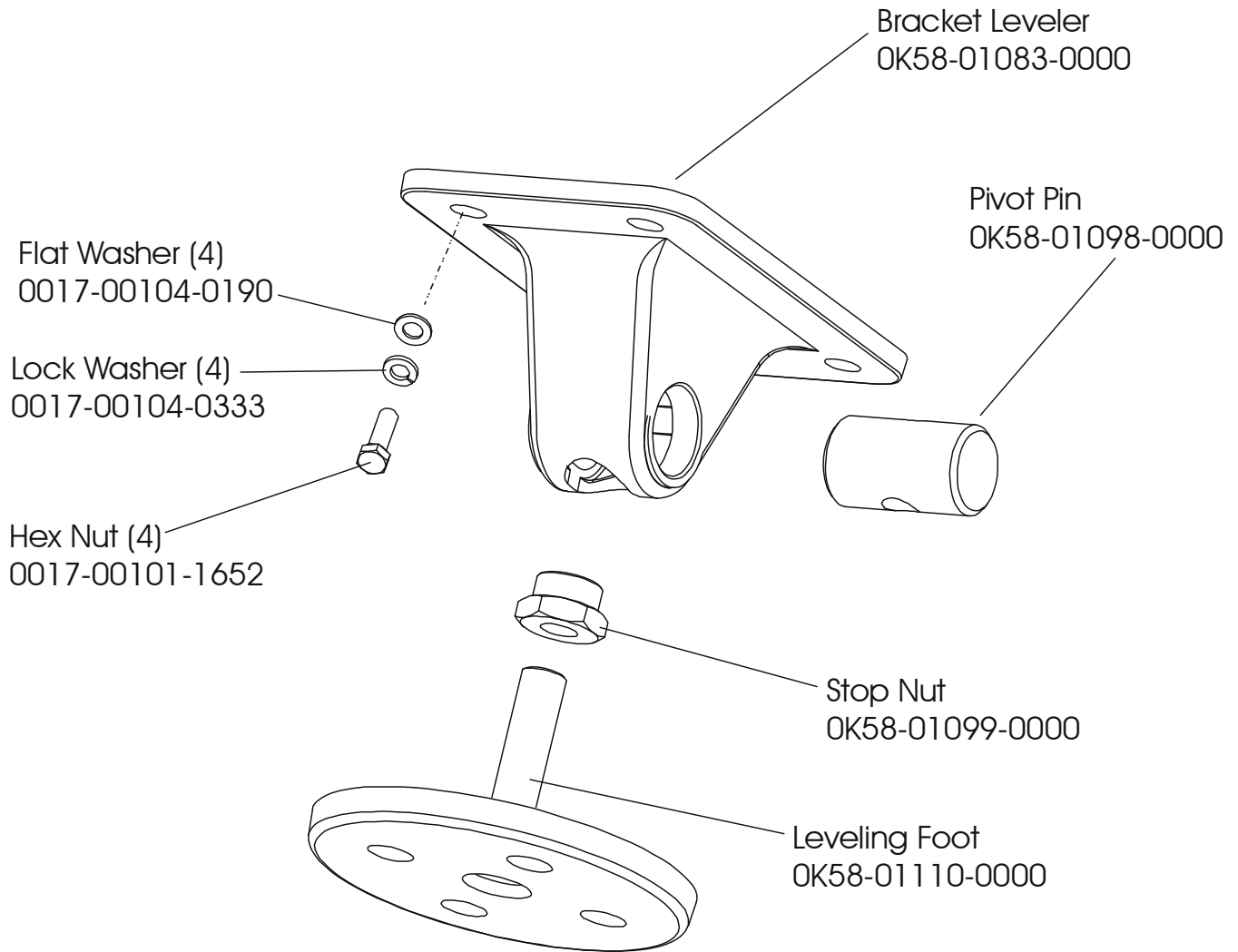

ARCTIC SILVER 93T
Front Roller Assy.-AK58-00066-0000

93T-0XXX-03
S/N ATS100000 and up

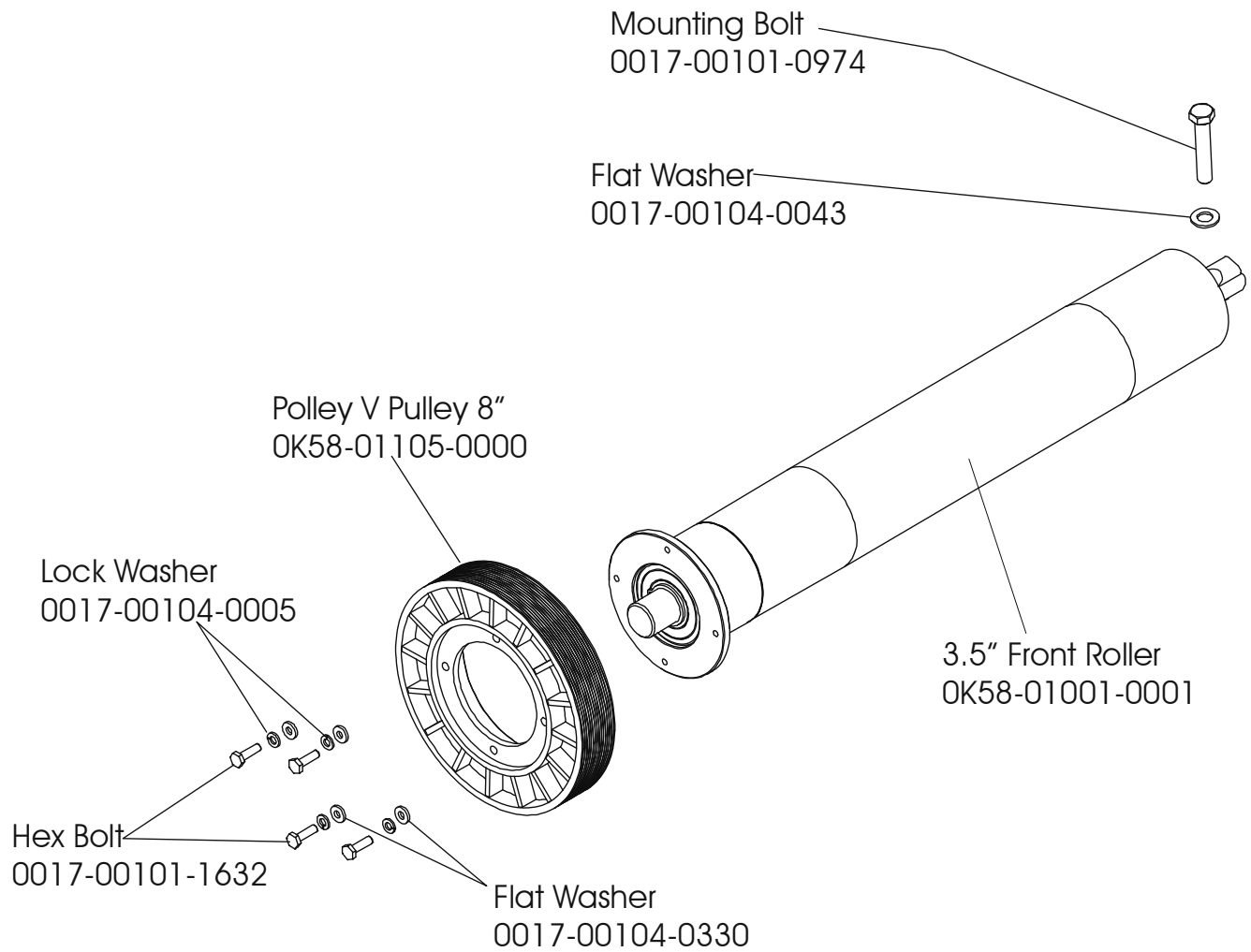

ARCTIC SILVER 93T

Power Components Schematic

93T-0XXX-03
S/N ATS100000 and up

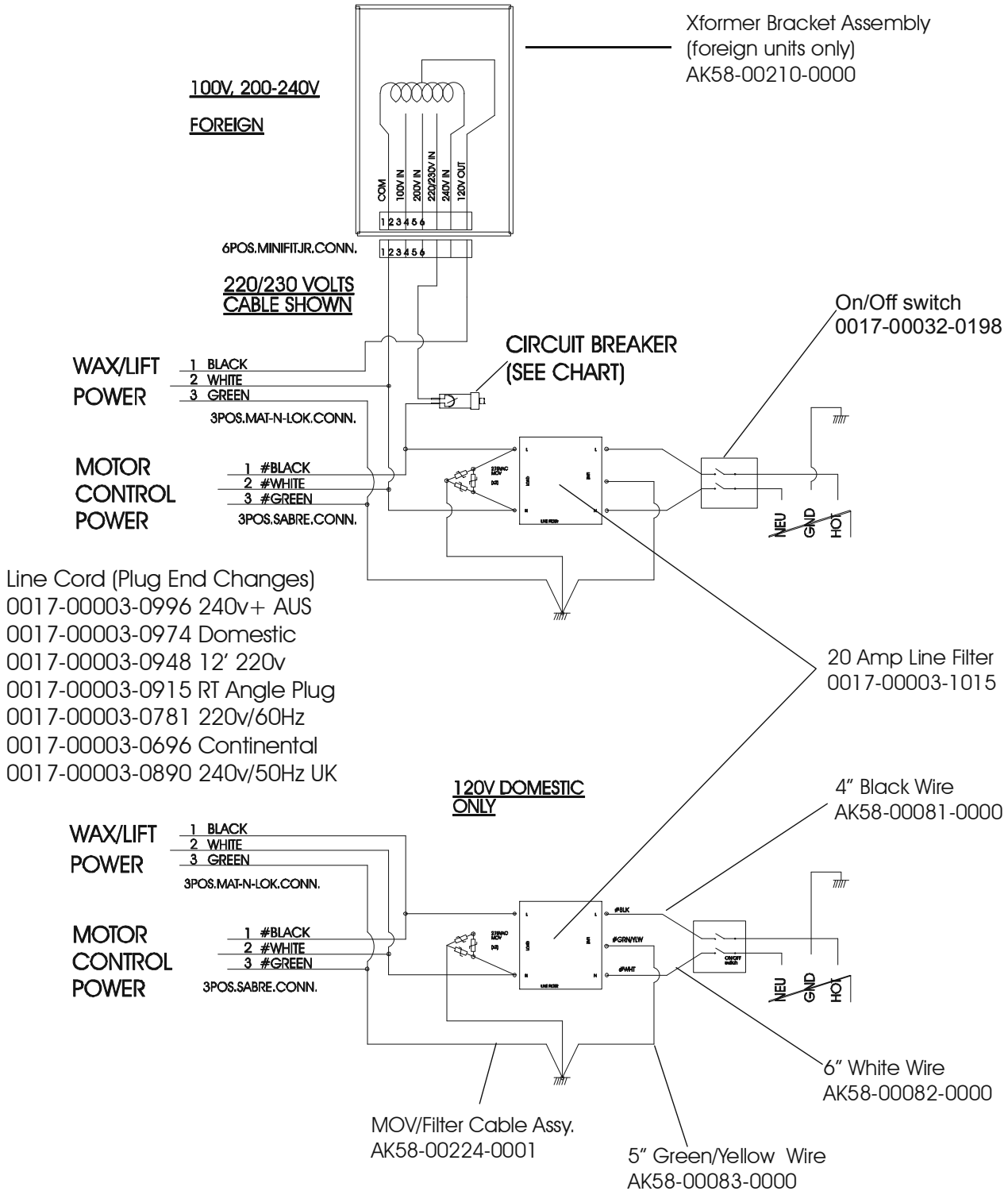

ARCTIC SILVER 93T

Wax/Lift Power Supply

93T-0XXX-03
S/N ATS10000 and up

